

2/2-Way, Stainless Steel, 1/2" – 2"



Advantages / Benefits

- ▶ Fluid is hermetically isolated from the actuator by diaphragm
- ▶ Automatic self-adjustment of basic parameters
- ▶ Integrated PID Controller
- ▶ User-friendly operation
 - LCD display
 - Key pad interface
 - Easy-to-understand menu-guided programming
- ▶ Code-protection against unauthorized access
- ▶ CE certified

Design

This proportional control system is a combination of a piston operated diaphragm valve with a uniquely formed stainless steel body and an electropneumatically operated, Type 1067 positioner. The positioner consists of three main parts: the valve stem position pickup, the electropneumatic control system and the micro-processor electronics. The valve stem position pickup, a linear potentiometer connected to the valve stem, feeds back the actual stem position to the positioner electronics. The micro-processor electronics compares the actual stem position to the set point given by a standard signal (4-20mA, 0-10V,...). In the case of a position difference, the electropneumatic control system corrects the stem position until the set point is reached.

The Type 1067 positioner also features a built-in process controller for the control of flow, temperature, pressure, etc.

- Programmable flow curves:
 - linear
 - equal percentage
 - freely programmable
- No air consumption at steady-state condition
- Excellent flow characteristic combined with flow rates higher than conventional diaphragm valves
- Integrated PID Controller
- Captured exhaust air
- Direct mounting, no tubing between positioner and valve

Applications

Fluids

Polluted, dirty, abrasive or high viscosity liquids up to 285°F.

Applications

- Textile dyeing and bleaching
- Food processing
- Chemical processing
- Water treatment
- Medical technology (Sterilizers)
- Pollution control equipment

Burkert Contromatic USA
2602 McGaw Avenue
Irvine, CA 92614
Tel. 949.223.3100
Fax 949.223.3198
www.burkert-usa.com

Burkert Contromatic Inc.
760 Pacific Road, Unit 3
Oakville, Ontario, Canada
L6L 6M5
Tel. 905.847.5566
Fax 905.847.9006

Diaphragm Valve System for Proportional Control

General Purpose

Type 2031

with Positioner

Technical Data Positioner Type 1067

Electrical Data

Voltage supply:	24 V DC
Power consumption:	< 10 W
Signal input for positioner:	Unit signal: 4–20 mA 0–20 mA 0–10 V
Binary input:	Configurable as normally open or closed contact
Connection:	Terminal strip Cable gland 2 x PG 9

Pneumatic Data

Instrument air:	Filtered compressed air, lubricated or non-lubricated
Air performance	
Air inlet valve:	$C_v = .035$
Exhaust valve:	$C_v = .040$

Internal air consumption at steady-state conditions:	Zero
Connection:	Female pipe thread, G 1/8"

Positioner Data

Overall dimensions:	5" x 3.2" x 3"
Body material:	Aluminum, laquered
Fluid plate material:	Aluminum, anodized
Weight of positioner:	Approx. 2.2 lb.
Rating:	NEMA 4
Operating temperature:	32°F to 140°F

Technical Data Control Valve 2031

Valve

Size	1/2", 3/4", 1", 1-1/4", 1-1/2", 2"
Control range:	Greater than 50:1
Flow features:	Modified equal percentage
Flow capacity:	See table page 4
Fluid temperature:	7°F to 284°F
Max. Operating pressure:	145 PSI (at ambient temperature)

Actuator

Actuator piston dia.:	See table page 3
Supply pressure:	65 PSI, min, 85 PSI, max
Function:	Normally closed

Functional Diagram

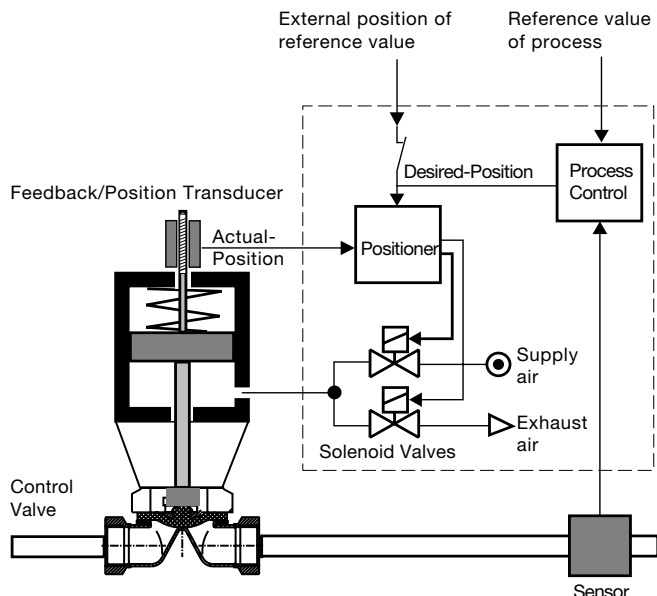

Material

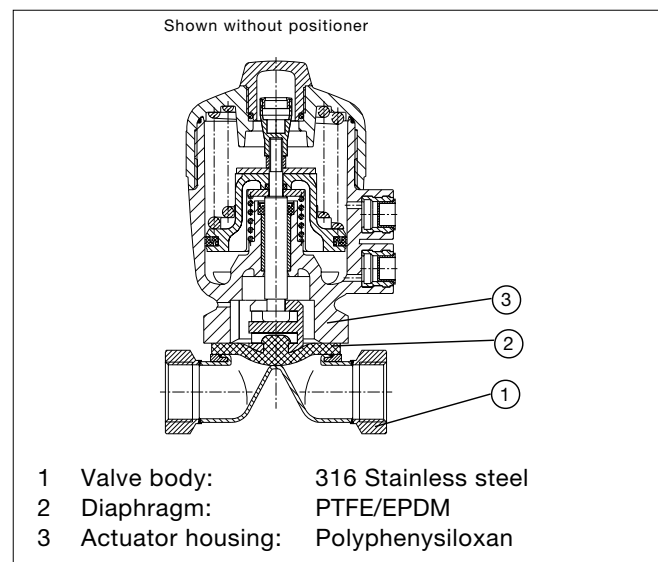

Ordering Chart

Valve Size [in.]	Actuator Piston Dia.	Max. operating pressure [psi]	Seal (Diaphragm)	Weight [lb.]	Item No.
1/2	2.48	145	EPDM	4.4	425 899 J
	2.48	128	PTFE/EPDM		425 900 X
3/4	3.15	145	EPDM	6.6	425 902 M
	3.15	145	PTFE/EPDM		425 903 N
1	3.15	145	EPDM	7.0	425 904 P
	3.15	100	PTFE/EPDM		425 905 Q
1 1/4	3.94	145	EPDM	10.8	425 906 R
	3.94	115	PTFE/EPDM		425 907 J
1 1/2	4.92	145	EPDM	15.0	425 909 U
	4.92	145	PTFE/EPDM		425 910 Q
2	4.92	125	EPDM	19.0	425 911 D
	4.92	100	PTFE/EPDM		425 912 E

Easy Pressure Control
Flow Control
Temperature Control

Easy to calibrate

Automatic self-adjustment of basic parameters by finger tip control

Easy to install

- Compact design
- Delivered pre-mounted, tested and ready to install
 - Requires less space than conventional control valves

Easy to operate

- User-friendly operation
- LCD and key pad interface
 - Menu-guided programming
 - Programmable characteristic curves

Easy to operate



Burkert control valve with Burkert digital flow transmitter for proportional process control.



Burkert Link

Specifications - Flow Capacity

Plug travel [%]	C _v -value					
	1/2"	3/4"	1"	1-1/4"	1-1/2"	2"
0	0.00	0.00	0.00	0.00	0.00	0.00
10	0.06	0.10	0.35	0.50	0.70	1.75
20	0.25	0.80	1.50	1.90	3.60	6.20
30	0.60	2.45	2.90	4.90	8.30	9.85
40	1.30	5.00	6.30	10.50	15.90	21.40
50	2.10	7.15	10.05	15.45	21.40	35.20
60	3.30	9.50	14.75	20.70	30.55	50.00
70	4.45	11.80	18.35	26.20	42.00	68.20
80	5.50	14.15	22.00	33.00	47.75	79.10
90	6.10	15.60	25.40	37.45	50.00	85.20
100	6.30	16.00	25.75	38.60	50.30	86.60

Dimensions [inch]

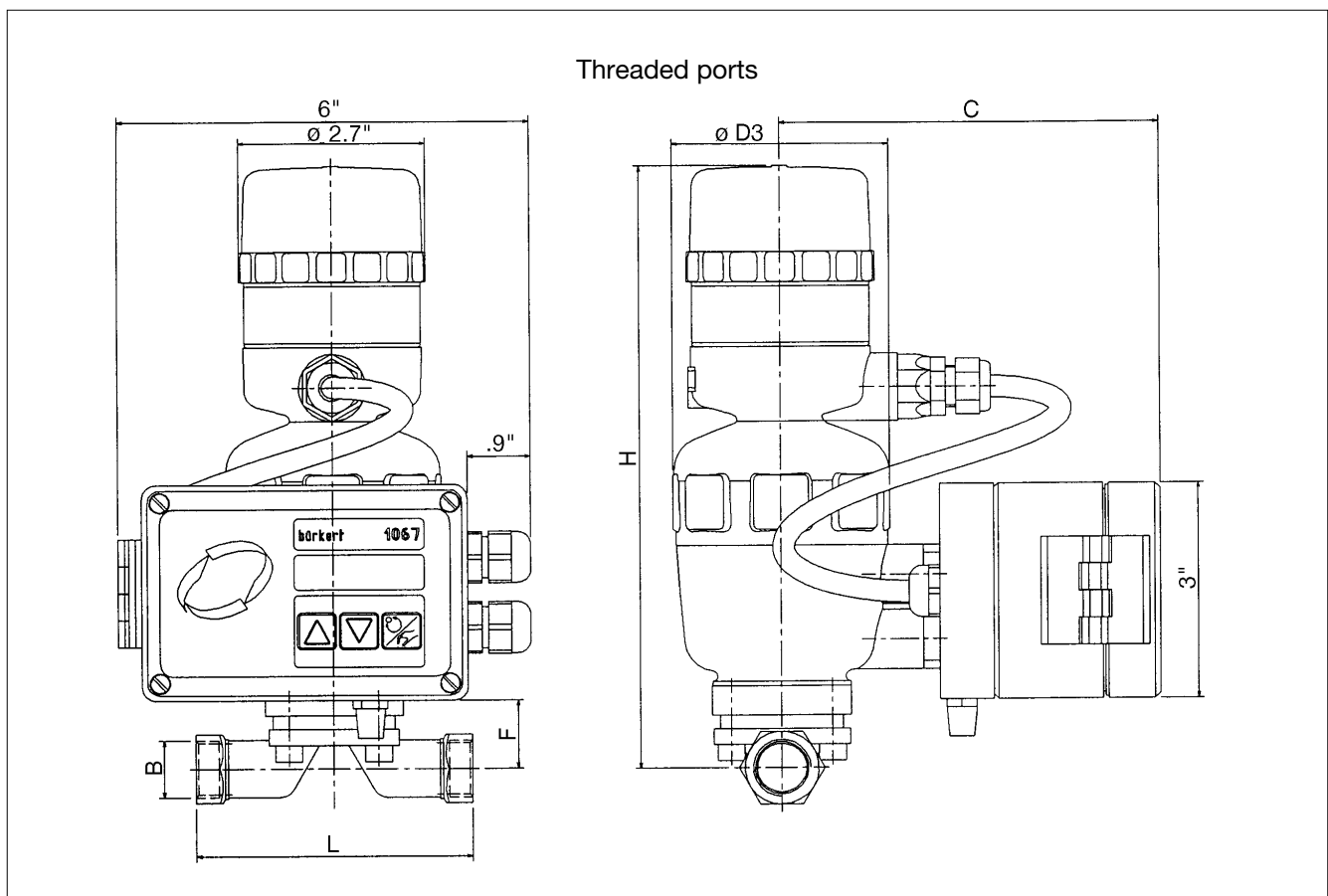

Variable dimensions [inch]

Valve Size B(NPT)	Actuator Piston Dia.	C	øD3	F	H	L
1/2	2.48	139	80	25.0	223	102
3/4	3.15	147	101	42.0	257	118
1	3.15	147	101	45.0	260	127
1-1/4	3.94	160	127	60.0	301	146
1-1/2	4.92	173	153	74.0	354	159
2	4.92	173	153	78.0	358	191