

### Non-contact Level Transmitter



### Design/Function

The Ultrasonic Level Transmitter Type 8170/8175 combines an ultrasonic sensor probe and a remote transducer with a large 8-digits multi-language display in a splash-proof plastic NEMA 4 enclosure for remote mounting.

The transmitter is powered with 18-32 VDC (optionally 120/240 VAC) and features a three-wire 4-20 mA output for direct controlling a continuous control valve, a PLC or for monitoring. Two optional 3A relays can be configured as alarms or latched for automatic fill or empty operations.

The transmitter Type 8170/8175 includes a range of fail-safe features. Signal loss, power supply failure, level or temperature alarm can be activated with an adjustable time delay. A range of filter functions control the return echoes and automatically eliminate all interferences due to elements of the vessel.

Easy and fast commissioning is guaranteed with the “Teach-In” and “Simulation” functions. Different tank shapes (cylindric, cubic, spheric) can easily be programmed via fixed default shapes. Complex tank shapes can be programmed using a step-by-step procedure.

The measured value can be read as a level, a distance (cm, m, inch or feet) or directly as a volume (liter, m<sup>3</sup>, imp. gal, us gal).

The simulation function permits testing the control system under dry-run conditions.

Burkert offers the Ultrasonic Level Transmitter together with process control valves as a complete, easy control system. Easy commissioning, installation and operation makes the Burkert level control system number one for low cost of ownership.

**Burkert Contromatic USA**  
2602 McGaw Avenue  
Irvine, CA 92614  
Tel. 949.223.3100  
Fax 949.223.3198  
www.burkert-usa.com

**Burkert Contromatic Inc.**  
760 Pacific Road, Unit 3  
Oakville, Ontario, Canada  
L6L 6M5  
Tel. 905.847.5566  
Fax 905.847.9006

### Advantages/Benefits



- ▶ Teach-In function for easy commissioning provides low Total Cost of Ownership
- ▶ Simulation function for system tests under dry run conditions



- ▶ Easy Link with 4-20 mA current output for continuous control and two relay outputs for ON/OFF control and fail-safe logic
- ▶ Easy commissioning due to multi language, menu-guided operation with 8-digit alphanumeric display
- ▶ Intelligent echo filter for automatic rejection of perturbing echoes
- ▶ CE

### Applications

- Non-contact continuous level or volume measurement with all liquids in open or closed vessels
- Flow measurement in open channels
- Distance and movement supervision
- Waste engineering, water treatment and process technology
- Food industry
- Chemical and pharmaceutical industry

**bürkert**  
*Easy* Fluid Control Solutions

# Ultrasonic Level Probe and Transmitter

## Remote Mounted

### The Easy Level Control System

#### *Easy* Continuous Pneumatic Control

Applications:

- Continuous chemical dosing
- Automatic continuous vessel filling

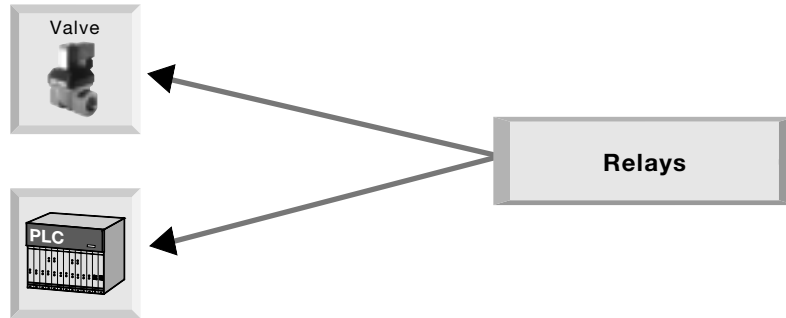

#### *Easy* Continuous Solenoid Control

Applications:

- Continuous chemical dosing
- Automatic continuous vessel filling

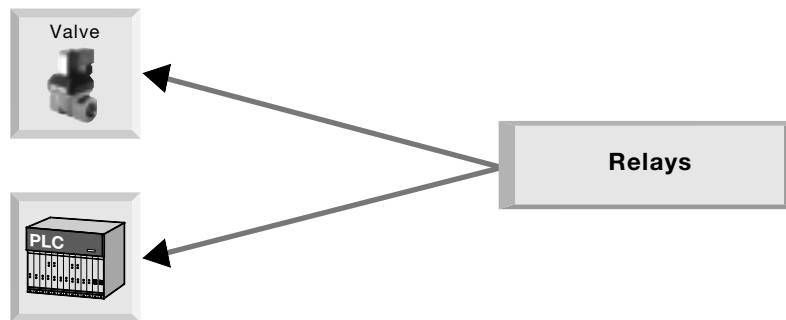

#### *Easy* ON/OFF Control

Applications:

- Fill / Empty control
- Overfill protection
- Monitoring

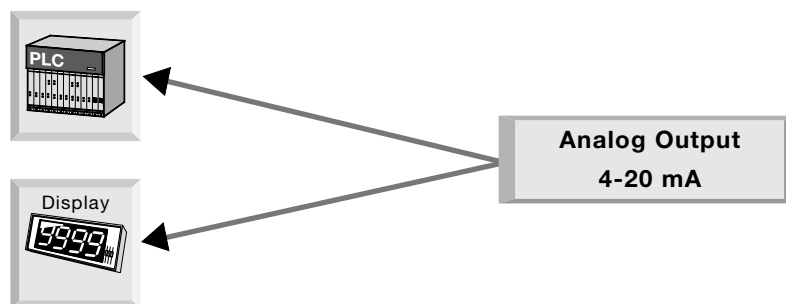

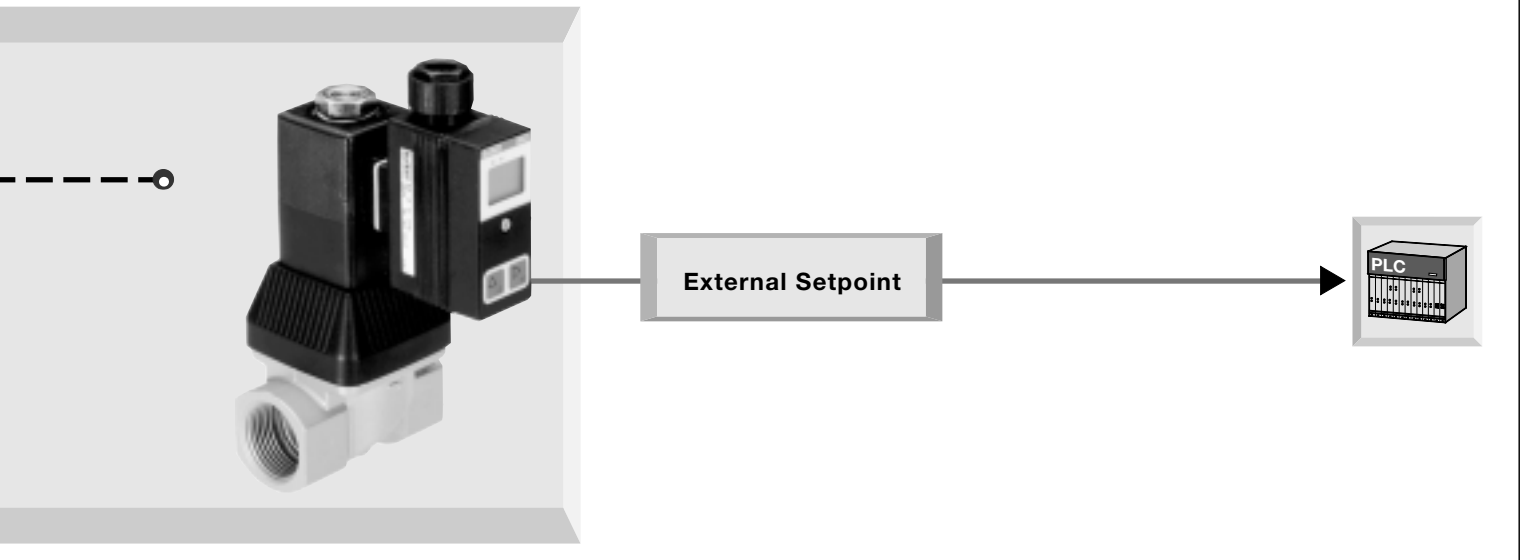
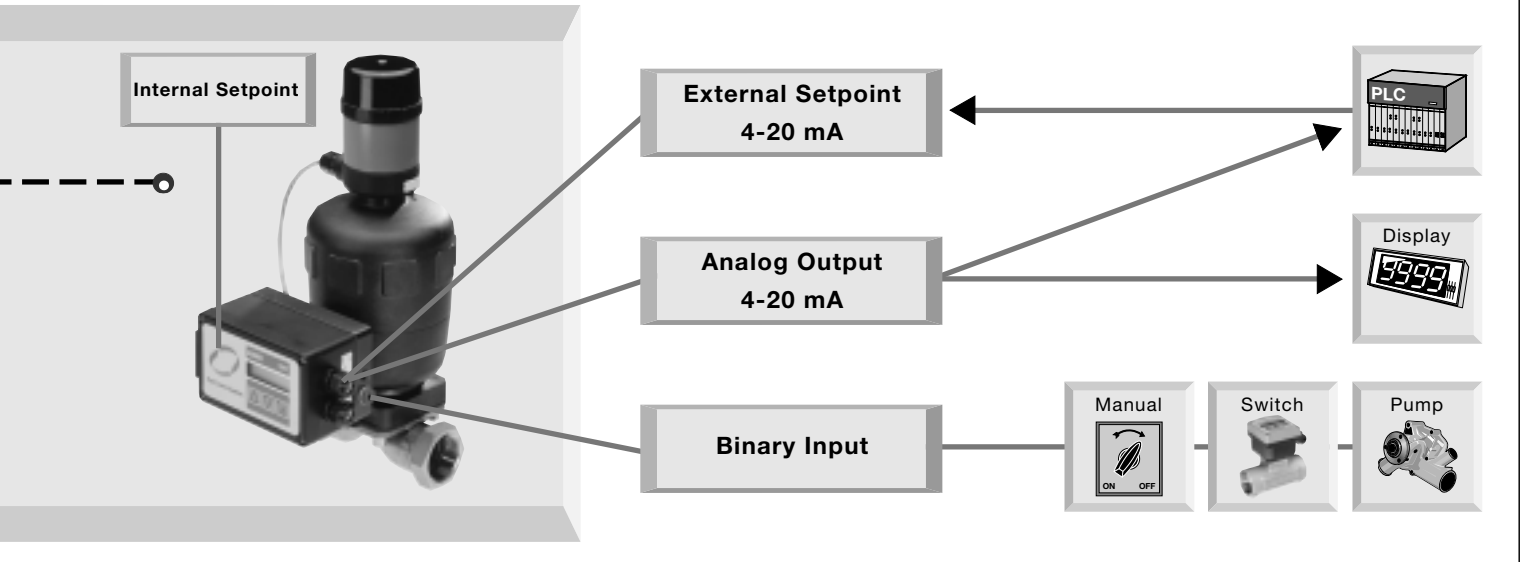

# Ultrasonic Level Probe and Transmitter

## Remote Mounted

**Type 8170/8175**  
*Easy* LEVEL

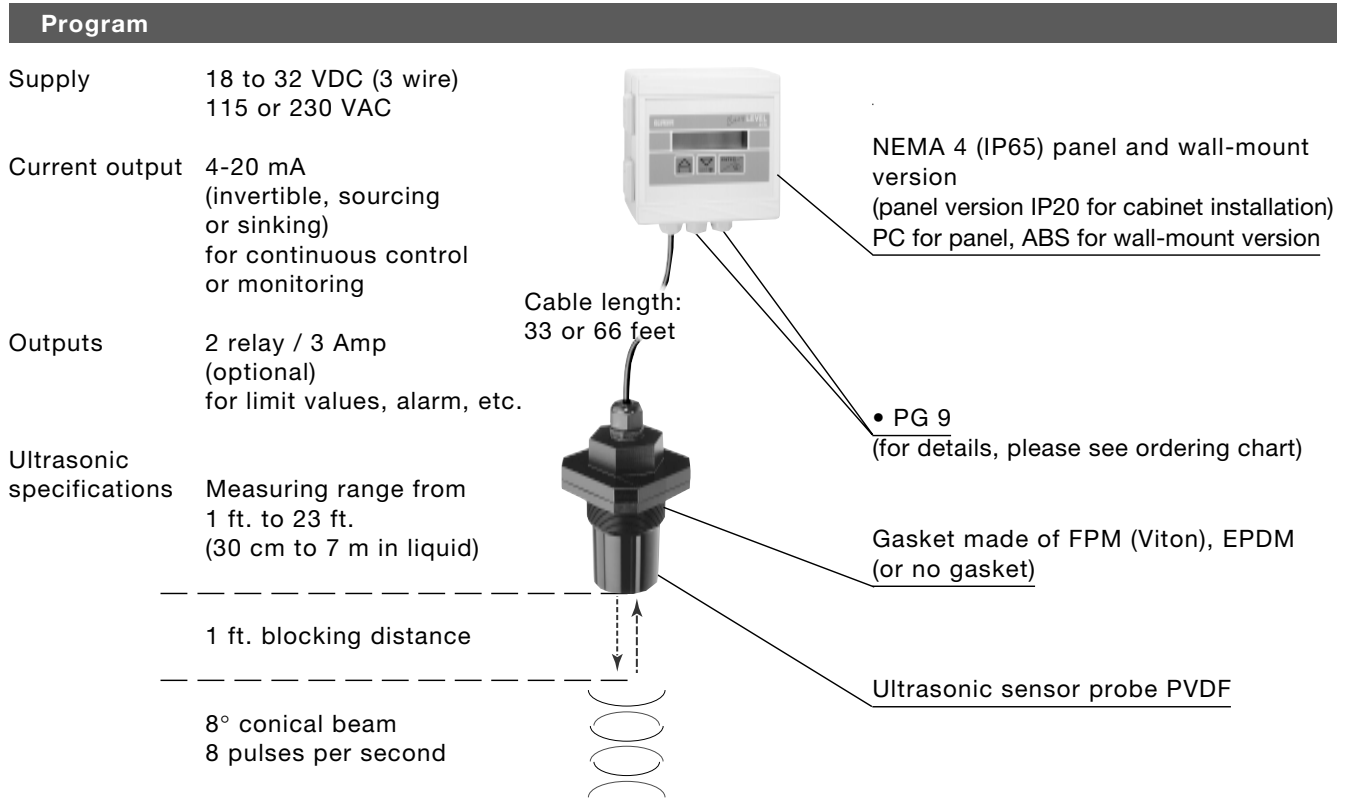

Technical Data			
Range	1 ft. to 23 ft. (0.30 to 7 meters)*	Medium temperature	-40°F to 176°F (-40°C to 80°C)
Accuracy	± 0.25% of full scale ± 0.15% of full scale with calibration in Teach-In mode	Ambient temperature	-4°F to 140°F (-20°C to 60°C)
Resolution	± 0.12 inch	Temperature adjustment	Programmable according to gas medium
Frequency	50 kHz	Pressure rating	Max. 29 PSI at 77°F (2 bar at 25°C)
Pulse rate	8 pulses per second	Transducer material	PVDF / POM (cover)
Full beam width	8 degrees conical	Enclosure material	PC for panel version ABS for wall-mount version
Blocking distance	1 foot from transducer base	Enclosure rating	NEMA 4 (IP65)
Display type	0.6 x 2.36 in. LCD 8 digits, alphanumeric 15 segments, 0.35 in. high	Mounting threads	G 2" or NPT 2"
Supply voltage	18-32 VDC or 115/230 VAC	Gasket material	FPM (Viton) or EPDM (or no gasket)
Current consumption	200 mA maximum	Signal invert	4-20 mA or 20-4 mA
Current flow	Sinking or sourcing	Relay output	2 relays; 3 A; freely adjustable
Signal output	4-20 mA alarm at 22 mA 18-32 VDC	Fail safe	
Load		Power loss	Relay automatically inverts to the NO safe position in the event of signal or power supply loss
at 32 V	Max. 1300 Ω	Signal loss	The relay takes the previously programmed safe position
at 24 V	Max. 1000 Ω		
at 18 V	Max. 550 Ω		

\* in reference conditions (77°F, 14.5 PSI in air, on liquid without foam)

**Operation and Display**

The unit is operated in the following 3 different modes:

**Operation Mode**

- Display of Level, distance or volume, in the required engineering unit (refer to the calibration menu).
- Gas temperature (unit per calibration menu).
- 4-20 mA output signal, proportional to the level per the selected measuring range.

**Calibration Mode**

- Language selection between English, German, French, Italian and Spanish
- Selection of engineering units to display, level, distance & volume
- Damping selection and delay time setting for signal failure alarm. There are 10 steps available
- Gas characteristics (speed of sound and temperature influence  $dv/dT^{\circ}F$  (or  $^{\circ}C$ ))
- Selection of target level, if there are any fixed echoes to be filtered and eliminated by the transmitter
- Manual / Automatic determination (Teach-In) of reference measuring points (level, distance or volume)
- Determination of 4-20 mA measuring range
- Parameter definition of relays (level, distance, volume,  $T^{\circ}$ , and / or failure alarm available)
- Return to operation mode and storage of new parameters

**Test Mode**

- Offset adjustment (4 mA)
- Span adjustment (20 mA)
- Temperature adjustment
- Signal strength display
- Entering level, volume or temperature to be simulated. The outputs will react in accordance to this input
- Reset of interference table or return to factory settings



**Display Type 8175**

- 8 digits alphanumeric

**Description of Buttons**

- Acceptance of chosen parameter or adjusted value
- LED relay 2 (contact closed)
- LED relay 1 (contact closed)
- Direction downwards in menu or sideways for digit selection
- Direction upwards in menu or choice of digit value Steps from 0 to 9

**Principle of Operation**

A high frequency ultrasonic sound wave is pulsed eight times per second from the base of the transducer. This sound wave reflects against the process medium below and returns to the transducer.

The microprocessor-based electronics measure the time of flight between the sound wave generation and receipt of the return signal, and translates this figure into the distance between transmitter and process medium below.

**Target Applications with Type 8170/8175**

- Continuous level measuring for fluids and solids
- ON/OFF level measuring for fluids and solids

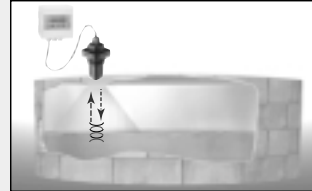

- Flow measurement in open channels

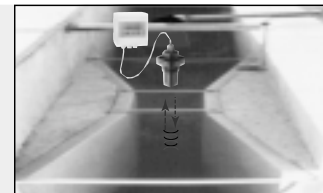

- Distance measuring



**Echo Filtering**

In case of specific applications with many obstacles, the Ultrasonic Level Transmitter Type 8170/8175 can adapt itself after entering just one calibration value.

After this operation, all echoes of fixed and intermittent obstacles are stored and rejected. This allows the installation of the Ultrasonic Level Transmitter Type 8170/8175 even in applications with obstacles in the beam cone like mounting elements, blades, agitators, etc.

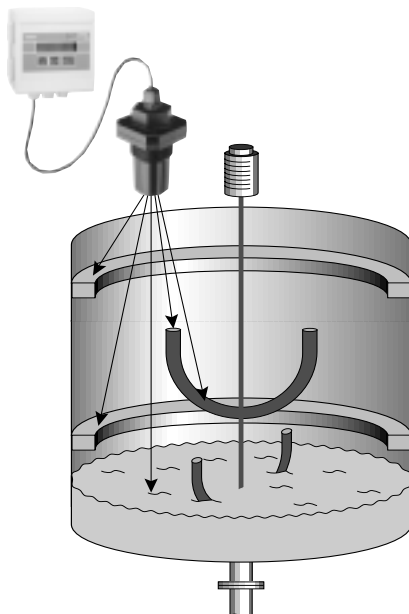

**Teach-In**

The Ultrasonic Level Transmitter Type 8170/8175 allows the measurement of distance, level or volume. In case of common tanks, entering the dimensions, for example the diameter of a cylindrical tank and a reference volume, is enough to proceed to the volume measurements. In case of unusual shapes, the Teach-In can be used to store the shape using an easy step-by-step technique.

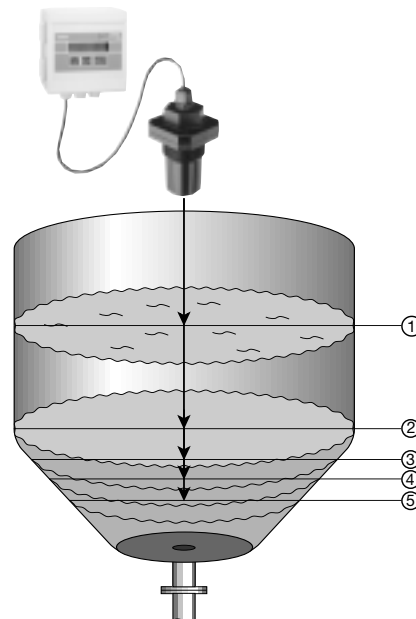

Dimensions [inch (mm)]

Remote control ultrasonic probe

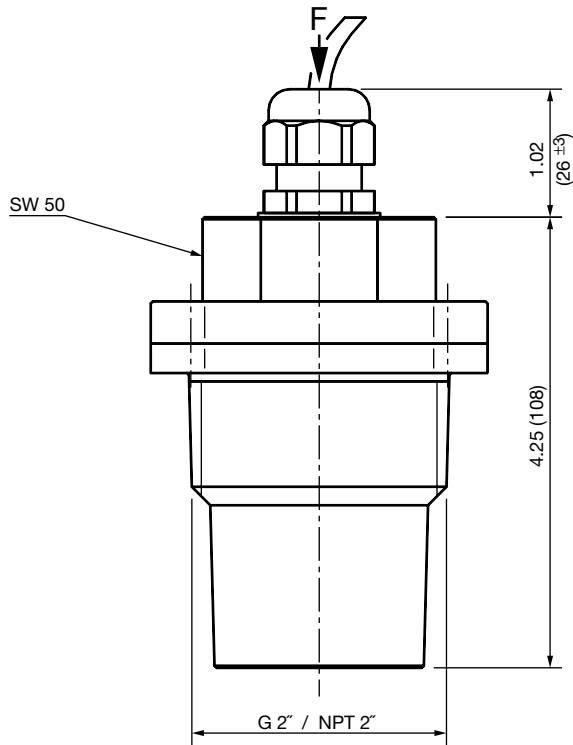

View F

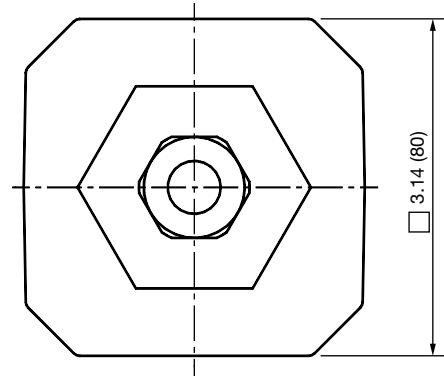

Remote control panel

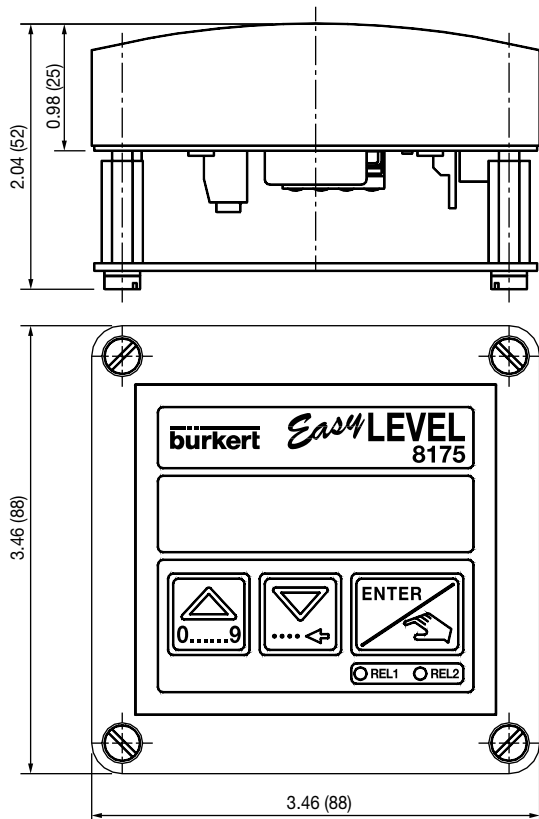

Remote control wall-mount version

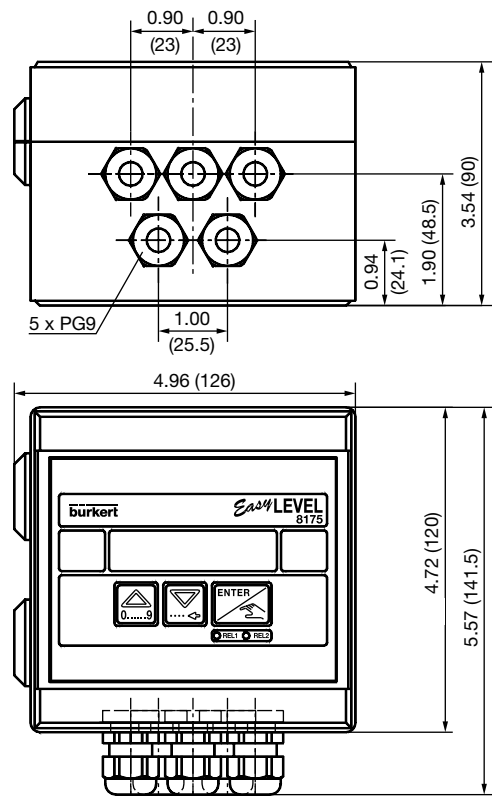

**Specifications - Ordering Chart (Other Versions on Request)**

**Probe, Panel Mount and Wall Mount Version**

**Probe Type 8170, G 2" mounting:**

Power Supply [V]	Mounting Threads [inch]	Relays	Connection	Item No.
-	G 2"	No	Cable, 33 ft. (10 m) length	436 563 K
-	G 2"	No	Cable, 66 ft. (20 m) length	436 564 L

**Probe Type 8170, NPT 2" mounting:**

Power Supply [V]	Mounting Threads [inch]	Relays	Connection	Item No.
-	NPT 2"	No	Cable, 33 ft. (10 m) length	436 565 M
-	NPT 2"	No	Cable, 66 ft. (20 m) length	436 566 N

**Panel Mount Version Type 8175 for Probe Type 8170:**

Power Supply [V]	Output Options	Relays	Connection	Item No.
18-32 DC	4-20 mA, 3 wire version	No	Terminal	436 567 P
18-32 DC	4-20 mA, 3 wire version	2	Terminal	436 568 Y

**Wall Mount Version Type 8175 for Probe Type 8170:**

Power Supply [V]	Output Options	Relays	Connection	Item No.
18-32 DC	4-20 mA, 3 wire version	No	5 x PG 9	436 569 Z
18-32 DC	4-20 mA, 3 wire version	2	5 x PG 9	436 570 W
115/230 AC	4-20 mA, 3 wire version	No	5 x PG 9	437 339 T
115/230 AC	4-20 mA, 3 wire version	2	5 x PG 9	437 340 G

**Ordering Chart Accessories**

Description	Item No.
2" FPM (Viton) seal	430 749 K
2" EPDM seal	430 750 Q
Cable plug DIN 43650 PG 9	424 205 Z
Cable plug DIN 43650 G 1/2"	424 206 S
Cable plug PG 13.5	418 339 G
Cable plug G 1/2"	418 340 M
Instruction manual for transmitter Type 8170 - 8175	427 998 P